

# Type CG Crossgard Clutch

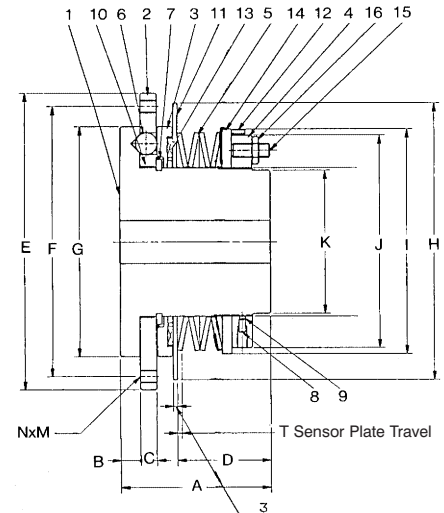

*Provides low cost overload protection with simple setting and operation, whilst maintaining synchronisation of driving elements*

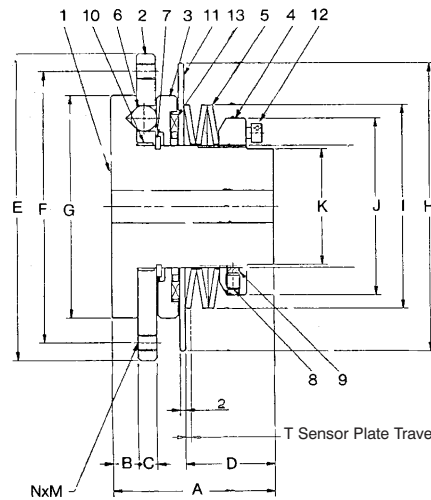

- 1 Hub
- 2 Centre Flange
- 3 Plate
- 4 Adjusting Nut
- 5 Disc Spring
- 6 Steel Ball
- 7 Snap Ring
- 8 Set Screw
- 9 Lock Plug
- 10 Skid Bearing
- 11 Sensor Plate
- 12 Indicator
- 13 Bearing
- 14 Pressure Plate
- 15 Adjusting Bolt
- 16 Adjusting Nut

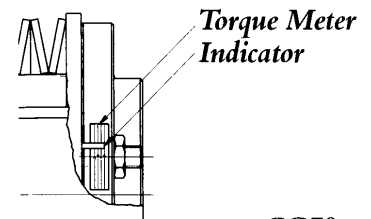
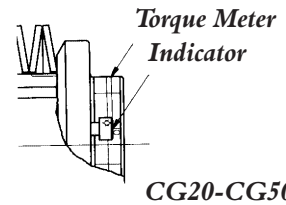

| Model                   | Torque NM        |                   | Max Speed RPM | Disc Spring Colour       | Bore Size |     | Weight kg. | Inertia kgm <sup>2</sup> (x10 <sup>-2</sup> ) |
|-------------------------|------------------|-------------------|---------------|--------------------------|-----------|-----|------------|---|
|                         | Min              | Max               |               |                          | Min       | Max |            |   |
| CG20                    | 9.6              | 45                | 700           | Orange                   | 8         | 22  | 0.9        | 0.23  |
| CG30L<br>CG30H          | 19.8<br>53.6     | 45<br>167         | 500           | Yellow<br>Orange         | 12        | 30  | 2.0        | 0.79  |
| CG50L<br>CG50M<br>CG50H | 68<br>136<br>196 | 147<br>407<br>540 | 300           | Yellow<br>Blue<br>Orange | 22        | 50  | 5.9        | 4.84  |
| CG70                    | 294              | 1080              | 160           | Orange                   | 32        | 70  | 17.0       | 25.2  |

Dimensions in mm

| Model | A   | B    | C    | D    | Eh <sub>7</sub> | F   | G   | H   | I   | J   | K    | M   | N (No.) | T   |
|-------|-----|------|------|------|-----------------|-----|-----|-----|-----|-----|------|-----|---------|-----|
| CG20  | 47  | 7.5  | 5.7  | 25.0 | 90              | 78  | 62  | 82  | 54  | 48  | 30   | M5  | 4       | 1.8 |
| CG30  | 60  | 9.5  | 7.0  | 33.0 | 113             | 100 | 82  | 106 | 75  | 65  | 42.5 | M6  | 6       | 2.0 |
| CG50  | 81  | 14.5 | 8.5  | 44.8 | 160             | 142 | 122 | 150 | 117 | 98  | 70   | M8  | 6       | 2.7 |
| CG70  | 110 | 14.5 | 12.0 | 68.5 | 220             | 200 | 170 | 205 | 166 | 157 | 106  | M10 | 6       | 3.3 |

### Dimensions for Mounting Drive Sprockets

| Model | A mm | B mm | C mm          | D mm | N |
|-------|------|------|---------------|------|---|
| CG20  | 65   | 78   | 90.06/ 90.02  | 5.5  | 4 |
| CG30  | 85   | 100  | 113.08/113.02 | 6.5  | 6 |
| CG50  | 125  | 142  | 160.10/160.02 | 9.0  | 6 |
| CG70  | 175  | 200  | 220.10/220.02 | 11.0 | 6 |

Driving members can be Timing Belt Pulleys, Vee-Belt Pulleys, Spur Gears or most common, Roller Chain Sprockets. For roller chain the minimum number of teeth sprocket which can be used is shown in the table below:

| Model | CHAIN PITCH (INCHES) |     |     |     |     |     |    |
|-------|----------------------|-----|-----|-----|-----|-----|----|
|       | 1/4                  | 8mm | 3/8 | 1/2 | 5/8 | 3/4 | 1  |
| CG20  | 48                   | 40  | 34  | 26  | 22  |     |    |
| CG30  | 60                   | 48  | 41  | 32  | 26  | 22  |    |
| CG50  |                      |     | 57  | 43  | 35  | 30  | 24 |
| CG70  |                      |     |     | 58  | 47  | 40  | 31 |

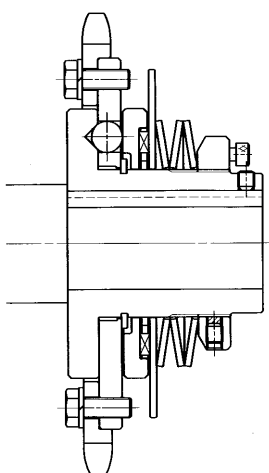
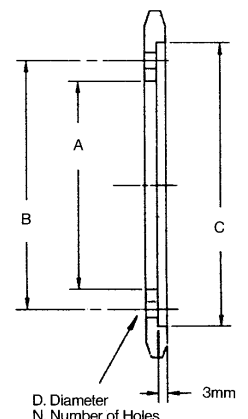

**Typical Sprocket Assembly**

Tel +44 121 360 0155

Fax +44 121 325 1079

Email sales@crossmorse.com