

Coupling selection

Selection of the POLY-NORM® coupling meets the DIN 740 part 2 specification. The coupling must be sized such that the coupling rated nominal torque is not exceeded in any operating condition. A comparison must be made between the application torque vs. the rating of the coupling. The selection process for torsionally flexible shaft couplings is described in detail in the ROTEX® catalogue which can be used for POLY-NORM® couplings as well.

Service factor S_t for temperature				
	-30 °C +30 °C	+40 °C	+60 °C	+80 °C
S_t	1,0	1,2	1,4	1,8

Service factor S_z for starting frequency				
starting frequency/h	100	200	400	800
S_z	1,0	1,2	1,4	1,6

Service factor S_A/S_L for shocks	
	S_A/S_L
gentle shocks	1,5
average shocks	1,8
heavy shocks	2,5

Example of calculation – Pump drive with three-phase motor

Given: Details of driving side

Power	$P = 75 \text{ kW}$	
Speed	$n = 1485 \text{ rpm}$	
Mass moment of inertia	$J_A = 1,06 \text{ kgm}^2$	$\Rightarrow S_A = 1,5$
Starting frequency	$z = 6^{1/6}$	$\Rightarrow S_z = 1,0$
Ambient temperature	$= + 60 \text{ °C}$	$\Rightarrow S_t = 1,4$

Given: Details of load side

Pump		
Nominal torque	$T_{LN} = 400 \text{ Nm}$	
Peak torque ¹⁾	$T_{LS} = 300 \text{ Nm}$	¹⁾ Peak value with shock load
Mass moment of inertia	$J_L = 2,3 \text{ kgm}^2$	$\Rightarrow S_L = 1,5$

Calculation

● Rated driving torque

$$T_{AN} [\text{Nm}] = 9550 \cdot \frac{P_{AN}[\text{kW}]}{n_{AN}[\text{rpm}]}$$

$$T_{AN} = 9550 \cdot \frac{75 \text{ kW}}{1485 \text{ rpm}} = 484 \text{ Nm}$$

Coupling selection

● Load produced by rated torque:

$$T_{KN} \geq T_{AN} \cdot S_t$$

$$T_{KN} \geq 484 \text{ Nm} \cdot 1,4 = 678 \text{ Nm}$$

Selected: POLY-NORM® AR Size 75:

$$T_{KN} = 850 \text{ Nm}$$

$$T_{K \text{ max}} = 1700 \text{ Nm}$$

● Load produced by torque shocks:

$$T_{K \text{ max}} \geq T_S \cdot S_z \cdot S_t$$

$$\text{Drive-sided shock } T_S = T_{AS} \cdot M_A \cdot S_A$$

● Driving torque:

$$T_{AS} = 2 \cdot T_{AN}$$

$$= 2 \cdot 484 \text{ Nm} = 968 \text{ Nm}$$

$$M_A = \frac{J_L}{(J_A + J_L)} = \frac{2,3 \text{ kgm}^2}{(1,06 \text{ kgm}^2 + 2,3 \text{ kgm}^2)} = 0,68$$

$$T_S = 968 \text{ Nm} \cdot 0,68 \cdot 1,5 = 987 \text{ Nm}$$

$$T_{K \text{ max}} \geq 987 \text{ Nm} \cdot 1 \cdot 1,4 = 1381 \text{ Nm}$$

$$T_{K \text{ max}} \text{ with } 1700 \text{ Nm} \geq 1381 \text{ Nm} \quad \checkmark$$

$$T_{K \text{ max}} \geq T_S \cdot S_z \cdot S_t$$

$$\text{Shock on driven side } T_S = T_{LS} \cdot M_L \cdot S_L$$

$$M_A = \frac{J_A}{(J_L + J_A)} = \frac{1,06 \text{ kgm}^2}{(2,3 \text{ kgm}^2 + 1,06 \text{ kgm}^2)} = 0,32$$

$$T_S = 300 \text{ Nm} \cdot 0,32 \cdot 1,5 = 144 \text{ Nm}$$

$$T_{K \text{ max}} \geq 144 \text{ Nm} \cdot 1,0 \cdot 1,4 + 400 \text{ Nm} \cdot 1,4 = 762 \text{ Nm}$$

$$T_{K \text{ max}} \text{ with } 1700 \text{ Nm} \geq 762 \text{ Nm} \quad \checkmark$$

Technical data

POLY-NORM® Technical data													
Size	Torque [Nm]			max. speed [rpm] at V = 30 m/s	Twisting angle with		Torsion spring stiffness C_{dyn} [Nm/rad]				Max. permissible misalignment (mm) ¹⁾		
	Nominal T_{KN}	max. $T_{Kmax.}$	Alternating T_{KW}		T_{KN}	$T_{Kmax.}$	1,0 T_{KN}	0,75 T_{KN}	0,5 T_{KN}	0,25 T_{KN}	Axial ΔK_a	Radial ΔK_r	Angular ΔK_w
28	40	80	16	8300			5200	3318	1867	897	± 1,0	0,20	1,2
32	60	120	24	7300	4,5	6,0	7820	4989	2821	1349	± 1,0	0,25	1,4
38	90	180	36	6500			13540	8639	4885	2336	± 1,0	0,25	1,5
42	150	300	60	5900			26250	16748	9471	4528	± 1,0	0,25	1,7
48	220	440	88	5400			29896	19074	10786	5157	± 1,5	0,30	1,8
55	300	600	120	4800			38500	24563	13891	6641	± 1,5	0,30	2,0
60	410	820	164	4400	4,0	5,5	67600	43129	23200	11661	± 1,5	0,30	2,2
65	550	1100	220	4100			81800	52188	26994	14111	± 1,5	0,35	2,4
75	850	1700	340	3600			122900	78410	40557	21200	± 1,5	0,40	2,7
85	1350	2700	540	3150			243045	155063	74858	41925	± 1,5	0,40	3,0
90	2000	4000	800	2900			361571	230682	111364	62371	± 1,5	0,45	3,4
100	2900	5800	1160	2600			548200	349752	168846	94565	± 3,0	0,50	3,9
110	3900	7800	1560	2300			792300	505487	244028	136672	± 3,0	0,60	4,3
125	5500	11000	2200	2050	2,5	3,5	1023240	652827	315158	176509	± 3,0	0,60	4,8
140	7200	14400	2880	1825			1640430	1046594	508533	282974	± 3,0	0,60	5,5
160	10000	20000	4000	1625			2090930	1334013	648188	360685	± 3,0	0,65	6,1
180	13400	26800	5360	1425			2670700	1703907	827917	460696	± 3,0	0,65	6,0

NEW
NEW
NEW

¹⁾ Misalignment at n = 1500 rpm.

Angular and radial misalignment can occur at the same time. The sum of all misalignments must not exceed the figures set forth in the table. Couplings may be dynamically balanced on request.

Misalignment

Axial misalignment ΔK_a

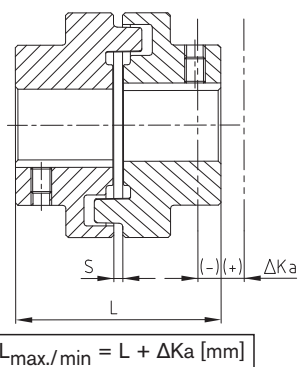

Radial misalignment ΔK_r

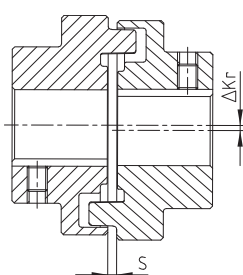

Angular misalignment ΔK_w

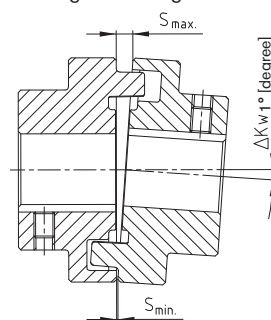

Assembly Guidelines

During assembly, the coupling halves must be mounted in a way that the coupling hub faces are flush to the end of the shafts. The alignment of the shafts must be adjusted that radial and the angular misalignments are minimal. The life of the coupling and bearings is extended by precise alignment. Steps must be taken to ensure that the alignment will not change during all operating conditions. Shaft misalignments which cannot be avoided must not exceed the figures indicated in the table. Angular and radial misalignments can occur at the same time but the sum of these misalignments must not exceed the figures set forth in the table above. See the KTR mounting instructions, KTR standard 49510 at our homepage www.ktr.com.

General information about the elastomer

Material/Hardness	Perbunan [NBR]/78 Shore A
Permanent temperature range [°C]	- 30 to + 80
Max. temperature (short time) [°C]	- 50 to + 120
Applications	General machine construction Pump industry ATEX applications Chemical industry Applications of average elasticity
Resistant to	Gasoline, diesel Acids, bases Tropics (Salt-) Water (hot/cold) Oils, greases Propane, butane Natural gas, city gas



Elastomer ring

Supplement to our programme: elastomers for the high-temperature range

Selection of standard IEC motors

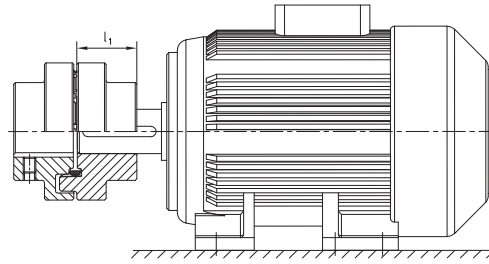

POLY-NORM® couplings for standard IEC motors, protection IP 54/IP 55 (elastomer ring 78 Shore A)														
A. C. motor 50 Hz		Motor output n = 3000 1/min 2-pole		POLY- NORM®- coupling size	Motor output n = 1500 1/min 4-pole		POLY- NORM® coupling size	Motor output n = 1000 1/min 6-pole		POLY- NORM® coupling size	Motor output n = 750 1/min 8-pole		POLY- NORM® coupling size	
Size	Shaft end d x l [mm]		Output P [kW]		Torque T [Nm]	Output P [kW]		Torque T [Nm]	Output P [kW]		Torque T [Nm]	Output P [kW]		Torque T [Nm]
	2-pole	4,6,8 pole												
56	9 x 20		0,09	0,32		0,06	0,43		0,037	0,43				
			0,12	0,41		0,09	0,64		0,045	0,52				
63	11 x 23		0,18	0,62		0,12	0,88		0,06	0,7				
			0,25	0,86		0,18	1,3		0,09	1,1				
71	14 x 30		0,37	1,3		0,25	1,8		0,18	2		0,09	1,4	
			0,55	1,9		0,37	2,5		0,25	2,8		0,12	1,8	
80	19 x 40		0,75	2,5	28/32	0,55	3,7	28/32	0,37	3,9	28/32	0,18	2,5	28/32
			1,1	3,7		0,75	5,1		0,55	5,8		0,25	3,5	
90S	24 x 50		1,5	5		1,1	7,5		0,75	8		0,37	5,3	
90L	24 x 50		2,2	7,4		1,5	10		1,1	12		0,55	7,9	
100L	28 x 60		3	9,8		2,2	15		1,5	15		0,75	11	
112M	28 x 60		4	13		3	20		2,2	22		1,1	16	
			5,5	18		4	27		2,2	22		1,5	21	
132S	38 x 80		7,5	25	38	5,5	36	38	3	30	38	2,2	30	38
132M	38 x 80					7,5	49		4	40		3	40	
									5,5	55				
160M	42 x 110		11	36	42	11	72	42	7,5	75	42	4	54	42
			15	49								5,5	74	
160L	42 x 110		18,5	60		15	98		11	109		7,5	100	
180M	48 x 110		22	71	48	18,5	121	48			48			48
180L	48 x 110					22	144		15	148		11	145	
200L	55 x 110		30	97		30	196	55	18,5	181	55	15	198	55
			37	120	55				22	215				
225S	55 x 110					37	240				60	18,5	244	60
225M	55 x 110	60 x 140	45	145		45	292	60	30	293		22	290	60
250M	60 x 140	65 x 140	55	177	60	55	356	65	37	361	65	30	392	65
280S	75 x 140		75	241		75	484	75	45	438	75	37	483	75
280M	75 x 140		90	289	65	90	581	75	55	535	75	45	587	75
315S	80 x 170		110	353		110	707	85	75	727	85	55	712	85
315M	80 x 170		132	423	75	132	849		90	873	85	75	971	
	65 x 140		160	513		160	1030		110	1070	90	90	1170	90
315L	65 x 140		200	641		200	1290	90	132	1280		110	1420	
					85				160	1550	100	132	1710	100
315	85 x 170		250	802		250	1600	100	200	1930	100	160	2070	100
			315	1010		315	2020		250	2410	110	200	2580	110
			355	1140	90	355	2280	110	315	3040	125	250	3220	125
355	75 x 140	95 x 170	400	1280		400	2570		400	3850		315	4060	
			500	1600		500	3210				140			140
			560	1790	100	560	3580	125	450	4330		355	4570	140
400	80 x 170	110 x 210	630	2020		630	4030		500	4810		400	5150	
			710	2270	110	710	4540	140	560	5390	160	450	5790	160
			800	2560		800	5120		630	6060		500	6420	
450	90 x 170	120 x 200	900	2880	125	900	5760	160	710	6830		560	7190	
			1000	3200		1000	6400		800	7690	180	630	8090	180

The arrangement of couplings is valid for an ambient temperature of up to + 30° C. For the selection there is a minimum safety factor of 2 of the max. coupling torque (Tk_{max}). A detailed arrangement is possible according to catalogue, page 51. Drives with periodical torque curves must be selected according to DIN 740 part 2. If requested, KTR will make the selection.

The coupling selection assumes normal operating conditions. Torque T = nominal torque according to Siemens catalogue M 11 · 1994/95.

Type AR



- Torsionally flexible, reduces vibrations
- Failsafe
- Maintenance-free
- Very short design
- Axial plug-in
- According to DIN 740
- Approved according to EC Standard 94/9/EC (Explosion Certificate ATEX 95)
- Detailed mounting instructions and further information available at www.ktr.com

Components

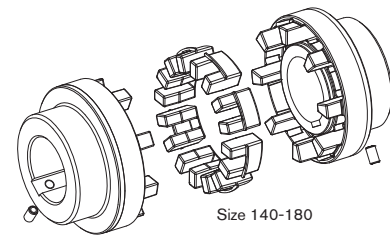
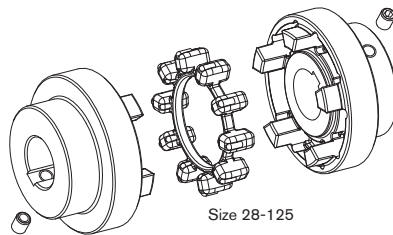
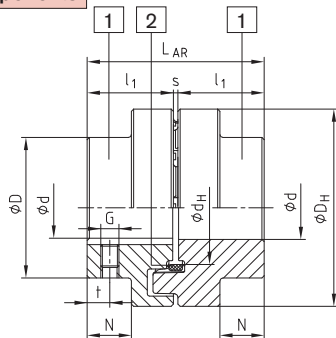

- Components:
Type AR
(EN-GJL-250)
(NBR 78 ShA)
- 1 = Standard hub
 - 2 = Elastomer ring

POLY-NORM® Type AR

Size	Elastomer ring (part 2) ¹⁾		Finish-bore Ø d _{max} ²⁾	Dimensions [mm]										Mass moment of inertia [kgm ²] ³⁾	AR ³⁾ Weight [kg]
	Torque [Nm]			General							Feststellgewinde ²⁾				
	T _{KN}	T _{K max.}		L _{AR}	l ₁	s	D _H	D	d _H	N	G	t			
28	40	80	28	59	28	3	69	46	36,5	12	M5	7	0,0004	0,9	
32	60	120	32	68	32	4	78	53	41,5	14	M8	7	0,0008	1,4	
38	90	180	38	80	38	4	87	62	50	19,5	M8	10	0,0016	2,0	
42	150	300	42	88	42	4	96	69	55,5	20	M8	10	0,0026	2,7	
48	220	440	48	101	48	5	106	78	64	24	M8	15	0,0042	3,7	
55	300	600	55	115	55	5	118	90	73	29	M8	14	0,0070	5,5	
60	410	820	60	125	60	5	129	97	81	33	M8	15	0,0112	6,9	
65	550	1100	65	135	65	5	140	105	86	36	M10	20	0,0174	8,8	
75	850	1700	75	155	75	5	158	123	100	42,5	M10	20	0,028	13,5	
85	1350	2700	85	175	85	5	182	139	116	48,5	M10	25	0,052	19,5	
90	2000	4000	90	185	90	5	200	148	128	49	M12	25	0,090	23,2	
100	2900	5800	100	206	100	6	224	165	143	55	M12	25	0,160	31,9	
110	3900	7800	50-110	226	110	6	250	185	158	60	M16	30	0,317	38,0	
125	5500	11000	55-125	256	125	6	280	210	178	70	M16	35	0,570	55,2	
140	7200	14400	65-140	286	140	6	315	235	216	76,5	M20	35	1,030	92,6	
160	10000	20000	75-160	326	160	6	350	265	246	94,5	M20	45	1,746	126,9	
180	13400	26800	75-180	366	180	6	400	300	290	111,5	M20	50	3,239	181,8	

¹⁾ Standard material perbunan (NBR) 78 Shore A, size 140 - 180 double tooth elastomers

²⁾ Bore H7 with keyway DIN 6885 sheet 1 [JS9] and threads for setscrews on the feather keyway.

³⁾ Refer to medium bore

Components

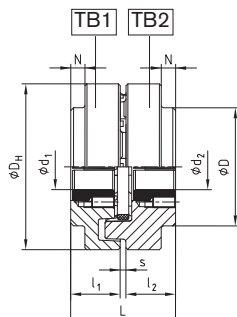

POLY-NORM® with taper clamping sleeve

Size	Taper clamping sleeve	Dimensions [mm]		Fixing screws ¹⁾ for taper sleeve				Size	Taper clamping sleeve	Dimensions [mm]		Fixing screws ¹⁾ for taper sleeve			
		max. d ₁ ; d ₂	l ₁ ; l ₂	Größe [Zoll]	Länge [mm]	SW [mm]	T _A [Nm]			max. d ₁ ; d ₂	l ₁ ; l ₂	Größe [Zoll]	Länge [mm]	SW [mm]	T _A [Nm]
32	1108	25	25,5	1/4"	13	3	5,7	85	2517	60	46,5	1/2"	25	6	49
48	1610	40	30,0	3/8"	16	5	20	90	3020	75	52,0	5/8"	32	8	92
60	1615	40	42,5	3/8"	16	5	20	100	3535	90	98,0	1/2"	38	10	115
75	2012	50	38,5	7/16"	22	6	31	125	4040	100	111,5	5/8"	45	12	172
75	2517	60	52,5	1/2"	25	6	49	¹⁾ 2 fixing screws except for 3535/4040 3 fixing screws.							

Coupling design
Combination possible

TB 1 Cam-sided screwing
Please ask for our separate data sheet M407045

TB 2 Verschraubung bundseitig

Order form:

POLY-NORM® 65	AR	Ø38	Ø30
Coupling size	Type	Finish bore	Finish bore

Type ADR (3-part design)



- Torsionally flexible, reduces vibrations
- Elastomer ring can be exchanged in assembled condition
- Failsafe
- Maintenance-free
- Short design
- Axial plug-in
- According to DIN 740
-  Approved according to EC Standard 94/9/EC (Explosion Certificate ATEX 95)
- Detailed mounting instructions and further information available at www.ktr.com

Components

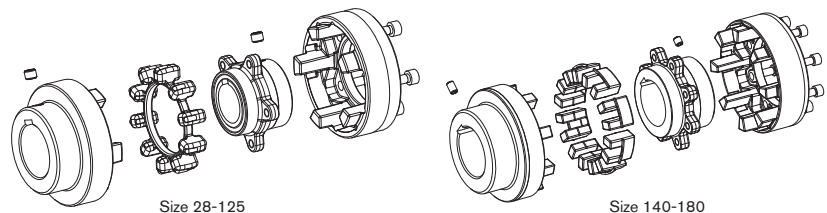
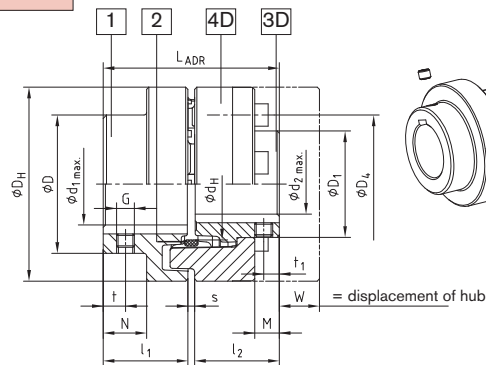

Components:

Type ADR (3-part)

- 1 = Standard hub (EN-GJL-250)
- 2 = Elastomer ring (NBR 78 SHA)
- 3D = Flange hub (EN-GJS-400-15)
- 4D = Cam ring (EN-GJL-250)

POLY-NORM® Type ADR

Size	Elastomer ring torque [Nm] ¹⁾		Dimensions [mm]															
			Finish bore ²⁾		General										Thread for setscrew			
			$d_1 \text{ max.}$	$d_2 \text{ max.}$	L_{ADR}	l_1/l_2	s	D_H	D	D_1	d_H	N	M	W	G	t	t_1	T_A [Nm]
38	90	180	38	32	80	38	4	87	62	48	50	19,5	11,0	12	M8	10	7	10
42	150	300	42	35	88	42	4	96	69	54	55,5	20	12,0	16	M8	10	7	10
48	220	440	48	42	101	48	5	106	78	62	64	24	13,7	16	M8	15	7	10
55	300	600	55	48	115	55	5	118	90	72	73	29	13,7	15	M8	14	14	10
60	410	820	60	55	125	60	5	129	97	80	81	33	22,2	14	M8	15	15	10
65	550	1100	65	60	135	65	5	140	105	86	86	36	26,7	11	M10	20	20	17
75	850	1700	75	65	155	75	5	158	123	98	100	42,5	27,8	16	M10	20	20	17
85	1350	2700	85	75	175	85	5	182	139	112	116	48,5	33,7	18	M10	25	25	17
90	2000	4000	90	85	185	90	5	200	148	122	128	49	31,5	26	M12	25	25	40
100	2900	5800	100	90	206	100	6	224	165	136	143	55	37,5	28	M12	25	25	40
110	3900	7800	110	100	226	110	6	250	185	150	158	60	39,5	30	M16	30	30	80
125	5500	11000	125	110	256	125	6	280	210	168	178	70	48,0	35	M16	35	35	80
140	7200	14400	65-140	55-130	286	140	6	315	235	195	216	76,5	47,0	59	M20	35	35	140
160	10000	20000	75-160	65-150	326	160	6	350	265	225	246	94,5	65,0	43	M20	45	45	140
180	13400	26800	75-180	65-170	366	180	6	400	300	255	290	111,5	79,0	33	M20	50	50	140

¹⁾ Standard material perbunan (NBR) 78 Shore A, size 140 - 180 double tooth elastomers

²⁾ Bore H7 with keyway to DIN 6885 sheet 1(JS9) with thread for set screws

Classification of cap crews DIN EN ISO 4762-12.9

Size	M x l [mm]	Number z	Separation z x angle	D_4 [mm]	T_A [Nm] ³⁾	Size	M x l [mm]	Number z	Separation z x angle	D_4 [mm]	T_A [Nm] ³⁾
38	M6x16	5	5x72	62	10	90	M16x30	6	6x60	149	210
42	M8x16	5	5x72	69	25	100	M16x30	6	6x60	163	210
48	M8x20	6	6x60	78	25	110	M16x40	8	8x45	183	210
55	M8x20	6	6x60	88	25	125	M20x40	8	8x45	202	410
60	M8x20	6	6x60	98	25	140	M20x50	8	8x45	237	410
65	M10x20	6	6x60	104	49	160	M20x55	9	9x40	267	410
75	M10x25	6	6x60	120	49	180	M20x60	10	10x36	304	410
85	M12x25	6	6x60	138	86						

Order form:

POLY-NORM® 65	ADR	$d_1 = \text{Ø}55$	$d_2 = \text{Ø}60$
Coupling size	Type	Finish bore part 1	Finish bore part 3D

Type AZR



- Connection of long shaft gaps with spacers
- Enables a change of the elastomer without disassembly of the drive and the driven components.
- No movement of driver and driven components is necessary for disassembly of pump thrust bearing.
- Custom designs are available (AZVR)
- Approved according to EC Standard 94/9/EC (Explosion Certificate ATEX 95)
- Detailed mounting instructions and further information available at www.ktr.com

Components

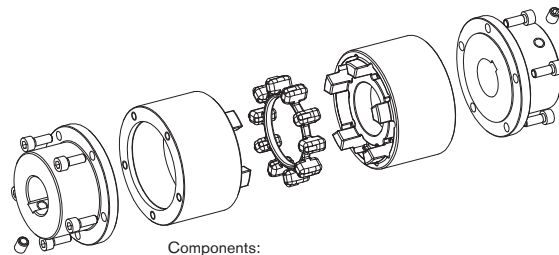
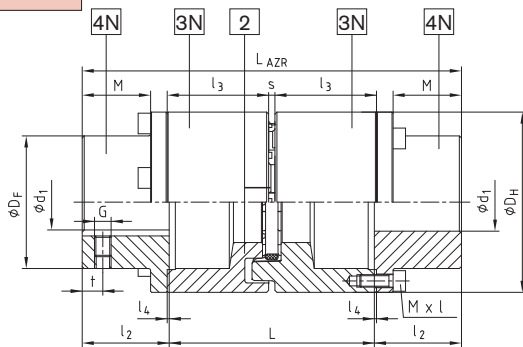

Components:

Type AZR

- 2 = Elastomer ring (NBR 78 Sha)
- 3N = Driving flange (EN-GJS-400-15)
- 4N = Coupling flange (S355J2G3)

POLY-NORM® Type AZR

Size	Drop out center length L [mm] *	Elastomer ring (p. 2) ¹⁾ torque [Nm]		Finish bore ²⁾ Ø d ₁ max	Dimensions [mm]													Mass moment of inertia ³⁾ [kgm ²]	AZR Weight ³⁾ [kg]
					General														
					T _{KN}	T _{Kmax}	L _{AZR}	l ₂	l ₃	s	l ₄	D _H	D _F	M	Mxl	T _A [Nm]	G		
28	100	40	80	30	170	35	49,5	3	1	69	46	26	M6x18	14	M5	7	0,0020	2,4	
	140				210		69,5										0,0030	2,9	
32	100	60	120	35	170	35	49	4	1	78	53	26	M6x18	14	M8	7	0,0042	3,2	
	140				210		69										0,0062	3,9	
38	100	90	180	40	184	42	49	4	1	87	62	33	M6x20	14	M8	10	0,0048	4,3	
	140				224		69										0,0068	5,1	
42	100	150	300	45	190	45	49	4	1	96	69	35	M6x20	14	M8	10	0,0094	5,1	
	140				230		69										0,0128	6,0	
48	100	220	440	50	204	52	49	5	1,5	106	78	41,5	M6x20	14	M8	15	0,0170	6,6	
	140				244		69										0,0216	7,5	
	100				210		49										0,0188	9,4	
55	140	300	600	60	250	55	69	5	1,5	118	88	43,5	M8x25	35	M8	14	0,0240	10,8	
	180				290		89										0,0232	12,2	
	100				220		49										0,0326	11,2	
60	140	410	820	65	260	60	69	5	1,5	129	97	47,5	M8x25	35	M18	15	0,0414	13,0	
	180				300		89										0,0504	14,6	
	100				230		49										0,0564	14,0	
65	140	550	1100	70	270	65	69	5	1,5	140	105	51,5	M8x25	35	M10	20	0,0730	15,8	
	180				310		89										0,0894	17,5	
	140				290		69										0,0824	23,2	
75	180	850	1700	80	330	75	89	5	1,5	158	123	60,5	M10x30	69	M10	20	0,1008	25,6	
	250				400		124										0,1332	29,8	
	140				310		69										0,1570	32,1	
85	180	1350	2700	90	350	85	89	5	1,5	182	139	69,5	M10x30	69	M10	25	0,1658	35,2	
	250				420		124										0,1812	40,7	
	140				320		69										0,2466	38,2	
90	180	2000	4000	100	360	90	89	5	1,5	200	148	73,5	M12x35	120	M12	25	0,2880	42,2	
	250				430		124										0,3566	49,3	
	140				340		69										0,3988	50,0	
100	180	2900	5800	110	380	100	89	6	2	224	165	83	M12x35	120	M12	25	0,4450	54,8	
	250				450		124										0,5465	63,2	

¹⁾ Standard material Perbunan (NBR) 78 Shore-A

²⁾ Bore H7 with keyway DIN 6885 sheet 1 [JS9] and threads for setscrews on the feather keyway.

³⁾ Refer to medium bore

*For other extendable lengths (L=120/160/195/215) it is possible to combine two driving flanges 3N with various lengths (as an example: driving flanges

POLY-NORM® 85 for extendable length 140 and 250 result in an extendable length of 195 mm (140 mm + 250 mm = 390 mm 390 mm/2 = 195 mm).

Order form:

POLY-NORM® 42	AZR	140	Ø38	Ø42
Coupling size	Type	Drop out center length L	Finish bore	Finish bore